

◆ 초음파 탐상용 용접 결함 시험편 ◆

Model: UT Kit

방사선 검사에서 사용되는 대표적인 용접 부를 종류별로 인공 결함을 종류별로 다양하게 제작한 뛰어난 교육 자료입니다. FlawTech 시험 편은 실질적인 용접에서 발생하는 모든 결함을 포함하는 시험편 입니다.



특징

- PIPE(1), TEE(1), PLATE(8) 총 10EA/SET로 구성.
- 시험편 내에 형태 및 크기, 위치가 다른 결함.
- 결함 위치 및 형태에 대한 촬영 필름 포함.
- 성적서 포함 .

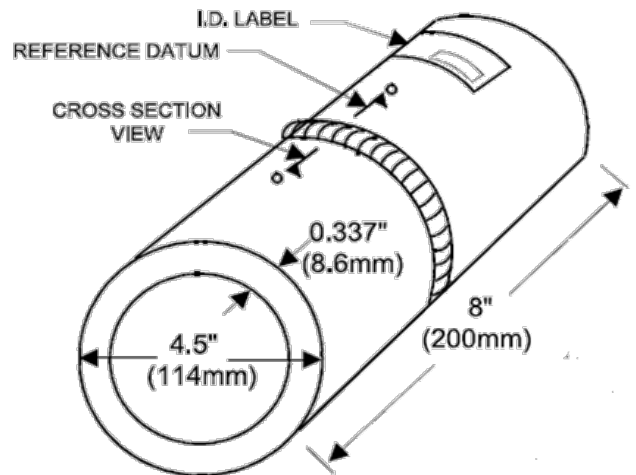
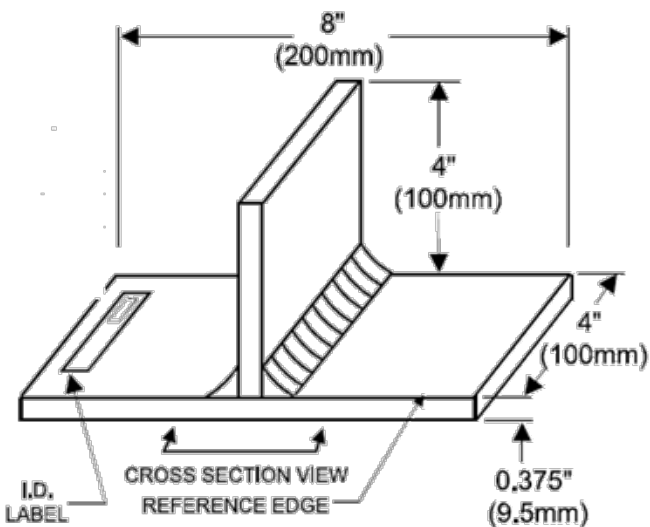
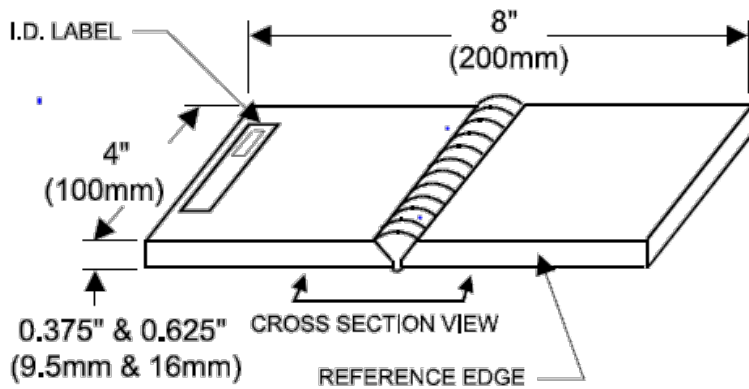

◆ 초음파 탐상용 용접 결함 시험편 ◆

Model: UT Kit



STANDARD ULTRASONIC KIT

The **Ultrasonic Kit** contains:
8 Plates, 1 Pipe and 1 Tee / Carbon Steel

Each specimen contains 2 "REAL FLAWS", randomly placed

Specimens are packaged in 2 **FREE CARRYING CASES**,
Complete with Document Package with "Flaw Truth" documented
by CAD drawings with a standard tolerance of $\pm 0.150"$ (4mm).

The Standard Ultrasonic Examination Kit contains 20 flaws
similar to those shown in the cross section drawings below.

VISIT FLAWTECH WEBSITE OR CALL FOR PRICE INFORMATION

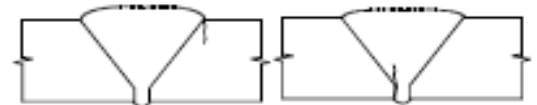

10. Toe Crack in Single Vee
MT/PT, UT

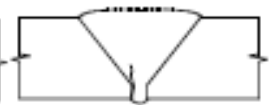

12. Root Crack in Single Vee
MT/PT, UT, RT

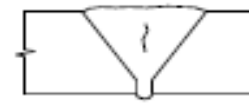

15. Centerline Crack, Single Vee
(sub-surface) UT, RT

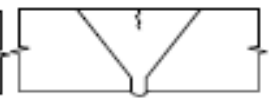

16. Circumferential Crack in
Single Vee, flush crown
MT/PT, UT

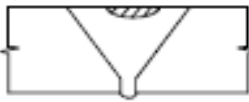

17. Transverse Crack in Single
Vee, flush crown
MT/PT, UT



18. Base Metal Crack in Single
Vee (top HAZ area)
MT/PT, UT

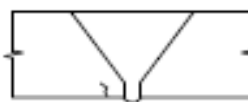

19. Base Metal Crack in Single
Vee (bottom HAZ area)
MT/PT, UT



30. Porosity in Double Vee
(sub-surface) UT, RT



31. Porosity in Fillet
(sub-surface) UT, RT

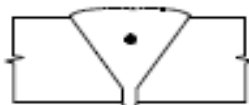

34. Single Gas Pore in Single
Vee UT, RT



37. Slag Inclusion in Single Vee
(weld groove area) UT, RT



38. Slag Inclusion in Fillet
(root area) UT, RT



50. Lamination in Single Vee
(base metal) UT



52. Lack of Fusion in Single Vee
(crown area) UT



55. Lack of Fusion in Single Vee
(surface breaking at root)
MT/PT, UT



56. Incomplete Root Penetration
in Single Vee, VT, UT, RT



57. Incomplete Root Penetration in
Double Vee, UT, RT



58. Incomplete Groove Weld
(crown area) VT, MT/PT, UT, RT

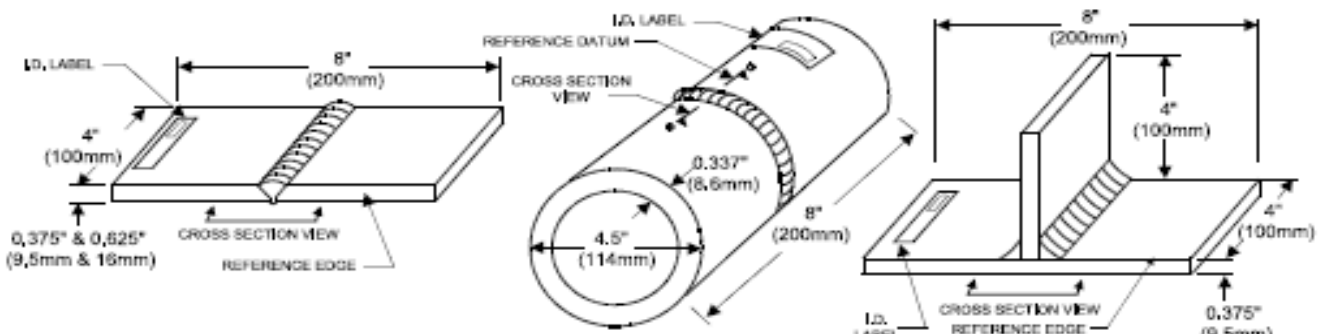

Shipping Weight 65lbs

ALL SPECIMENS CONTAIN
"REAL FLAWS"

CONTACT YOUR LOCAL NDT
SUPPLIER OR
FLAWTECH FOR ORDERING DETAILS

◆ 초음파 탐상용 용접 결함 시험편 ◆

Model: 주문 제작

Outline of Test Piece

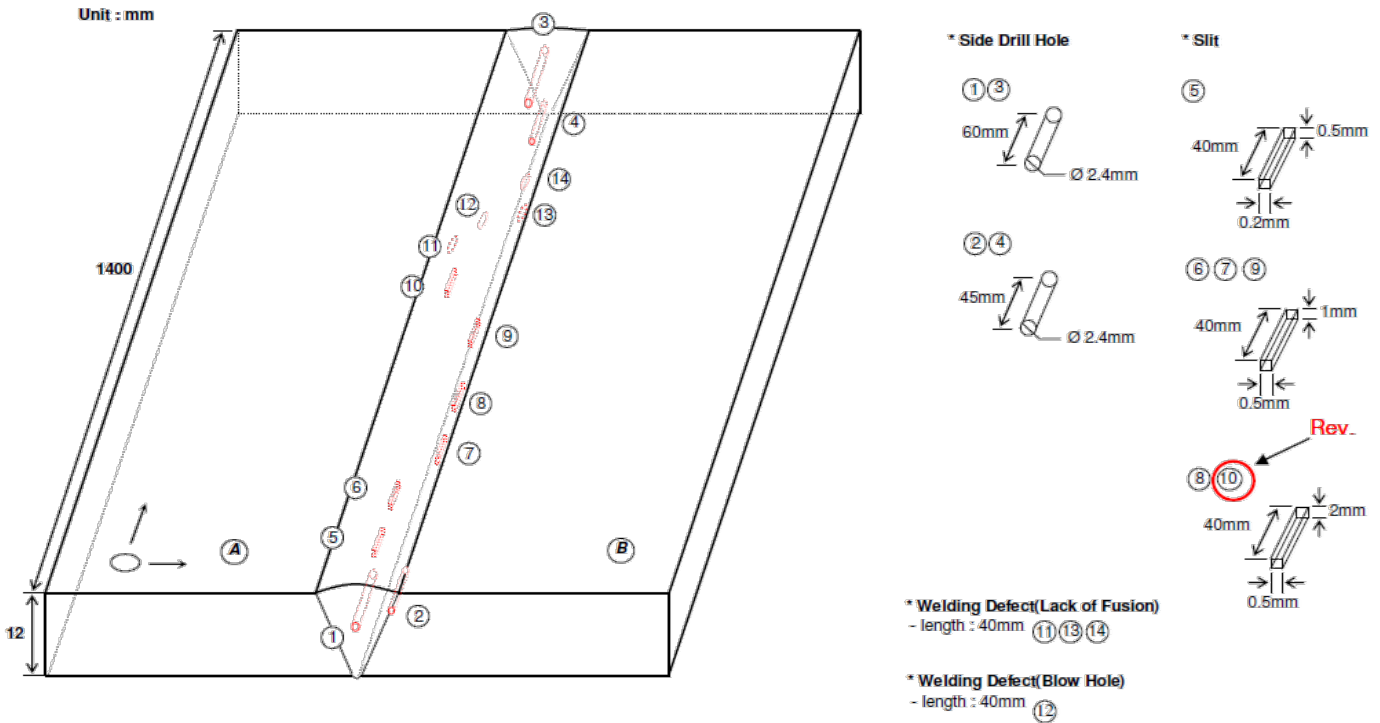

Ground Plan View of Test Piece

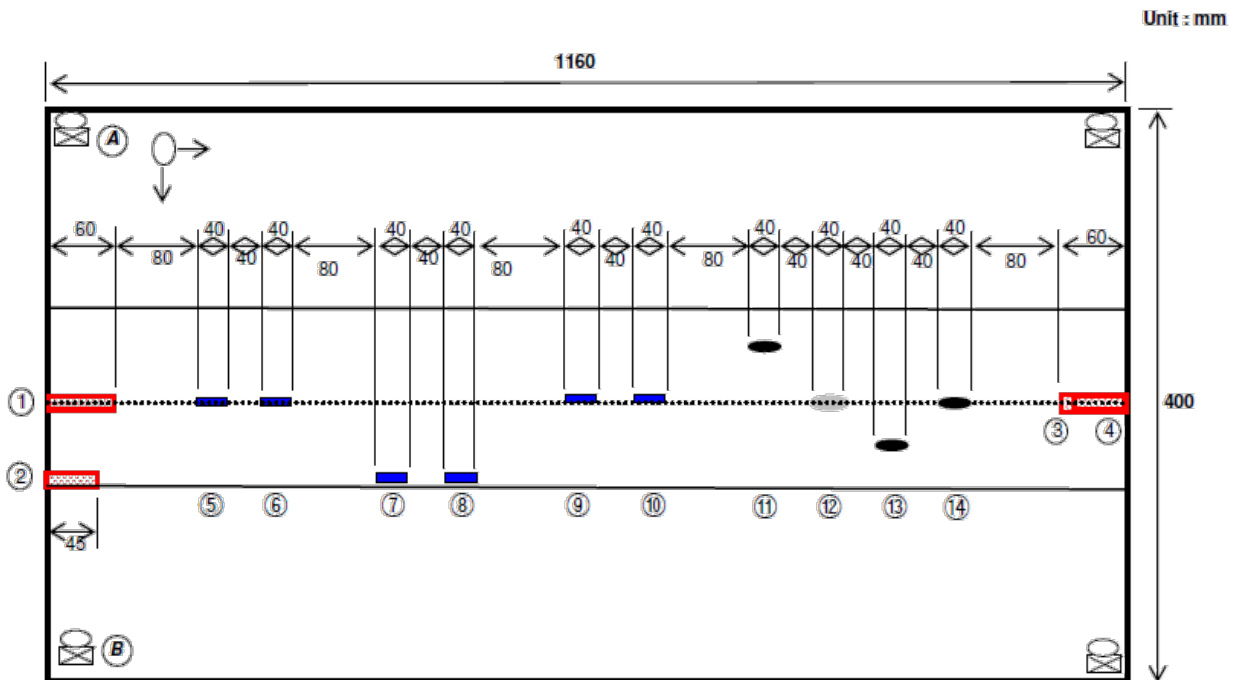

◆ 초음파 탐상용 용접 결함 시험편 ◆

Model: 주문 제작

■ Front View of Test Piece

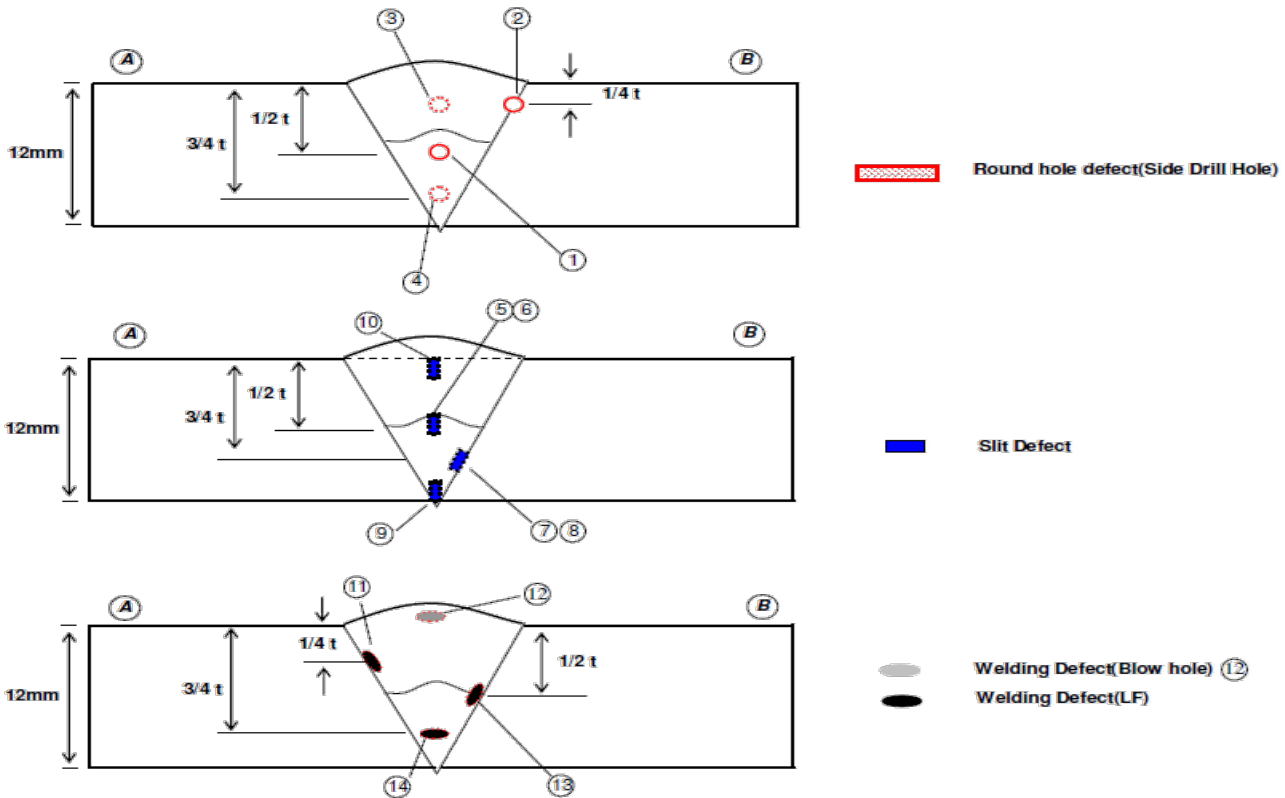

■ Joint Detail

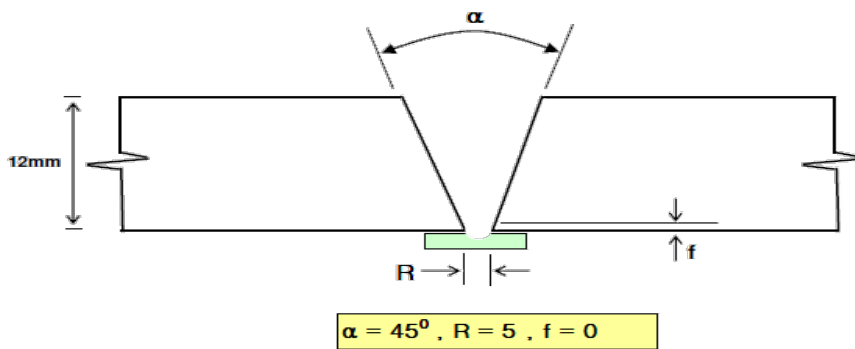

PQR data

Thickness (mm)	Backing	Welding Process	Filler Metal	Welding Position	Base metal
12	ceramic backing	FCAW	E308LT-1	1G,2G,3G	SUS 304