

STANDARD ULTRASONIC KIT

The **Ultrasonic Kit** contains:
8 Plates, 1 Pipe and 1 Tee / Carbon Steel

Each specimen contains 2 **"REAL FLAWS"**, randomly placed

Specimens are packaged in **2 FREE CARRYING CASES**.
Complete with Document Package with "Flaw Truth" documented
by CAD drawings with a standard tolerance of $\pm 0.150"$ (4mm).

The Standard Ultrasonic Examination Kit contains 20 flaws
similar to those shown in the cross section drawings below.

VISIT FLAWTECH WEBSITE OR CALL FOR PRICE INFORMATION

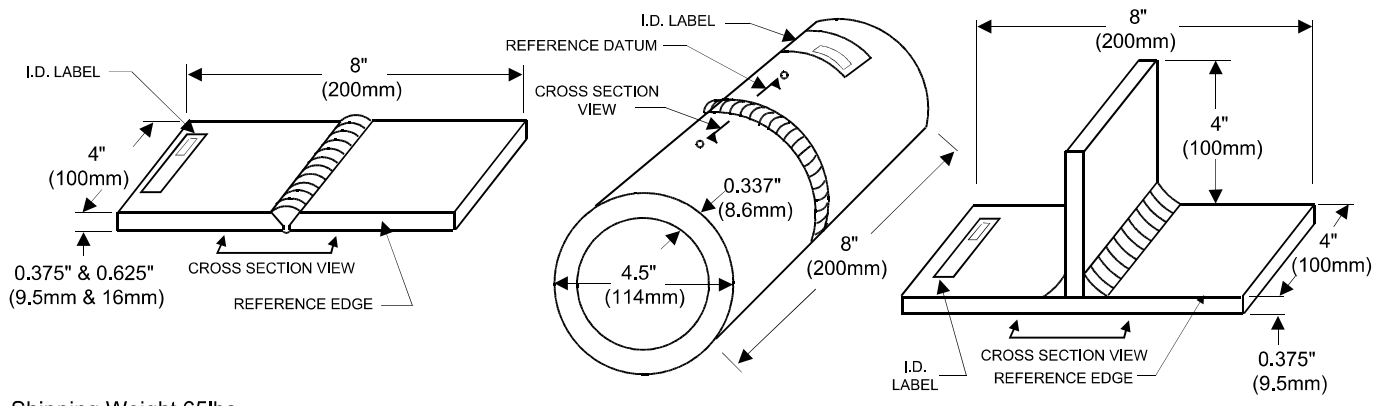
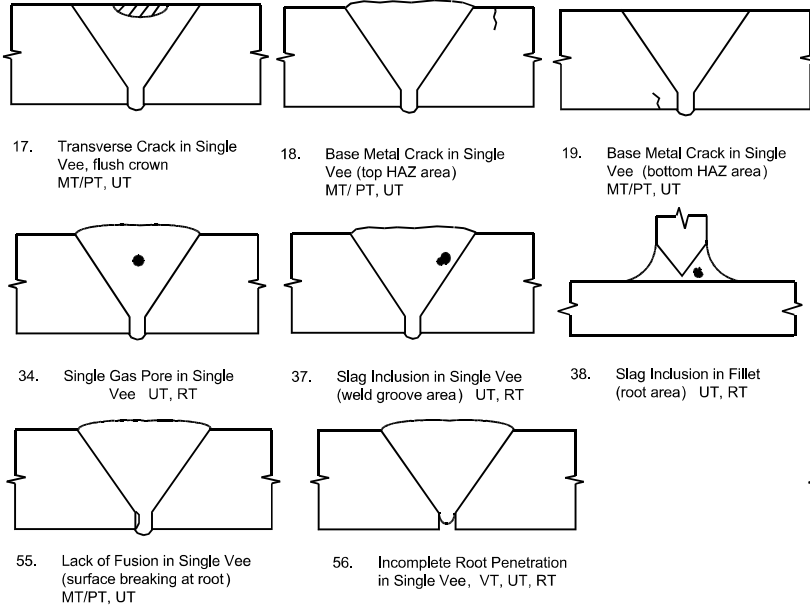
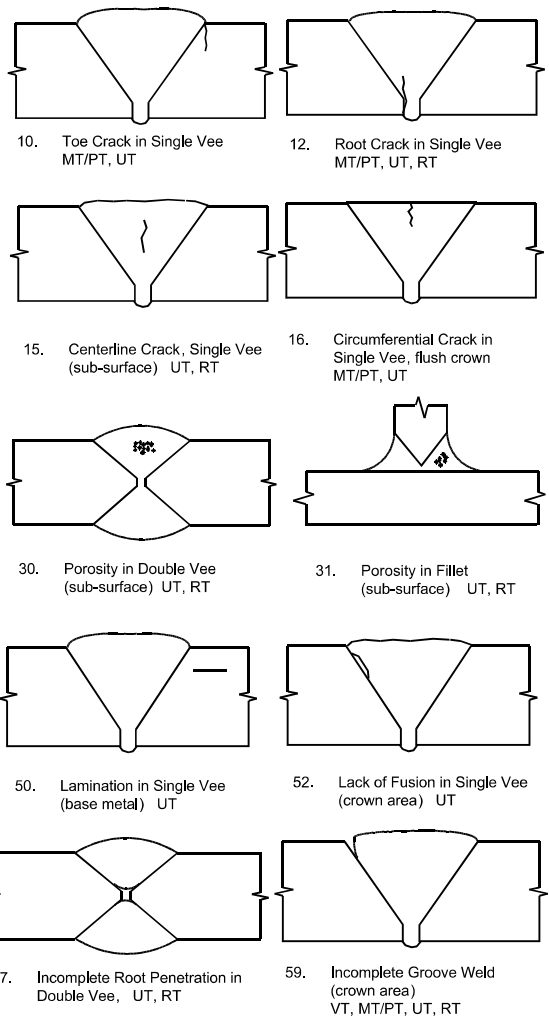

Shipping Weight 65lbs

Drawings Not to Scale

**ALL SPECIMENS CONTAIN
"REAL FLAWS"**

**CONTACT YOUR LOCAL NDT
SUPPLIER OR
FLAWTECH FOR ORDERING DETAILS**