

## UltraVision® 3

### Complete UT and Phased Array Inspection Package

#### Features & Benefits

- **PC based software**  
Operates efficiently on powerful laptops as well as high-end desktops, under various Windows® operating systems
- **Designed for performance**  
Supports a wide variety of advanced phased array UT methodologies, in addition to conventional UT
- **3D work environment for**  
Phased array probe and inspection technique development, inspection capability assessment, data visualization in realistic geometry
- **Software Development Kit (SDK)**  
Allows advanced users to implement their own features
- **Reliable and secure**  
User rights access management, raw data protection, software operation log,...

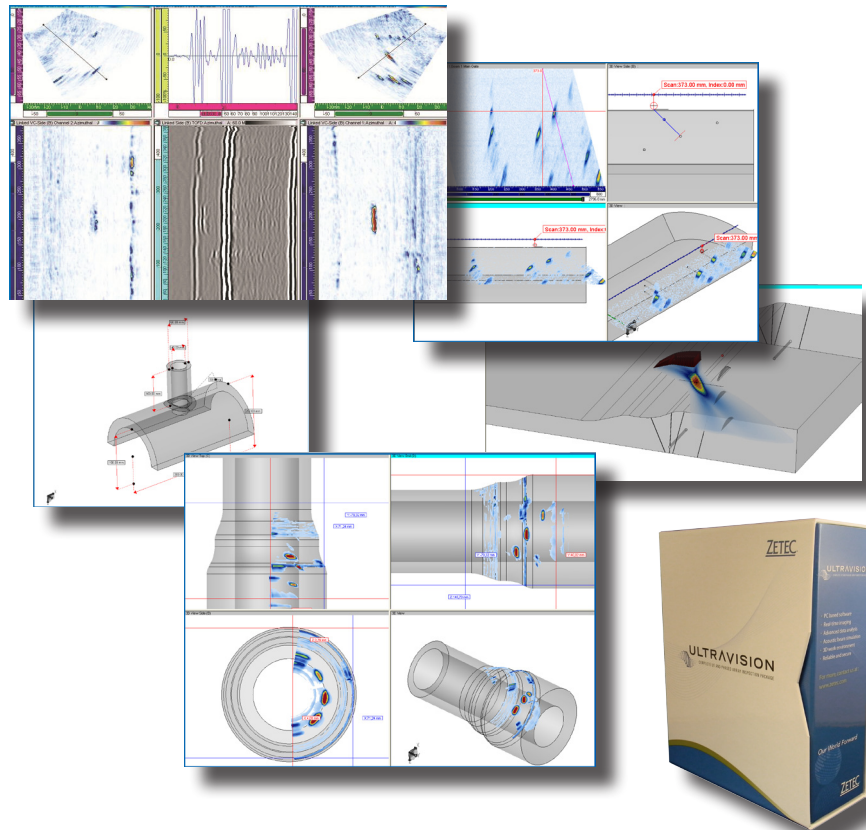

#### Efficient UT Inspection in a 3D Environment

Zetec's UltraVision 3 software manages ultrasonic (UT) signal acquisition, displays real-time imaging of these signals, and provides online as well as offline data analysis. UltraVision offers many advanced features and tools that improve the efficiency of UT inspections.

The UltraVision 3 software drives all Zetec's in-house phased array UT and conventional UT systems. In data analysis mode it supports legacy file formats (DAT, RDT, OPD and OUD) in addition to the new UVData and BeamData formats. The look-and-feel of UltraVision 3 will be very familiar for the seasoned UltraVision 1 user.

The integrated 3D work environment allows you to create your actual inspection configuration in UltraVision 3, and perform ray tracing with coverage mapping to determine your detection capability and inspection coverage.

The 3D data analysis features include visualization of the inspection data in the actual component, detection of suspected indications as well as the discrimination between actual flaw indications and signals originating from component geometry and weld structure. UltraVision 3 measures length and through-wall size of flaws. Inspection parameters and results are delivered in a comprehensive report format.

All system operations have a similar interface that eliminates additional training when operators switch from one acquisition unit to another.

An ideal tool for either on-site inspections or lab work, it operates with Microsoft® Windows® XP, Windows® Vista and Windows 7. UltraVision 3 requires a powerful laptop or a high-end desktop workstations. It can handle large data files with 16-bit amplitude resolution, up to 20 GB.

# UltraVision® 3

## Prepare and implement your UT examinations in a 3D world

- COMPONENT GENERATION**

You can use a predefined component that you can scale to your requirements, import a suitable CAD file (\*.SAT), or create one from a manual surface profile thus creating a custom specimen to apply. You can add defects in the inner structure of the component that will interact with incident rays. Visualizing your component in 3D allows you to better prepare your inspection configuration.

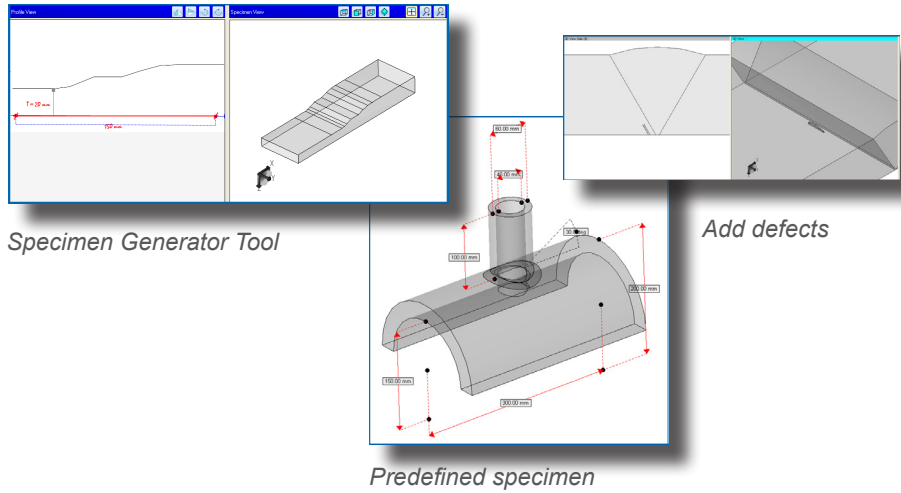

- 3D RAY-TRACING**

Computes and displays 3D ultrasound rays propagating in your specimen. The ray paths can undergo reflection and transmission, including mode conversions, and interact with postulated defects in simple or complex geometries. This tool helps you determine the optimal rays for the detection of the considered defects, and thus which ultrasonic beams to use for adequate inspection capability.

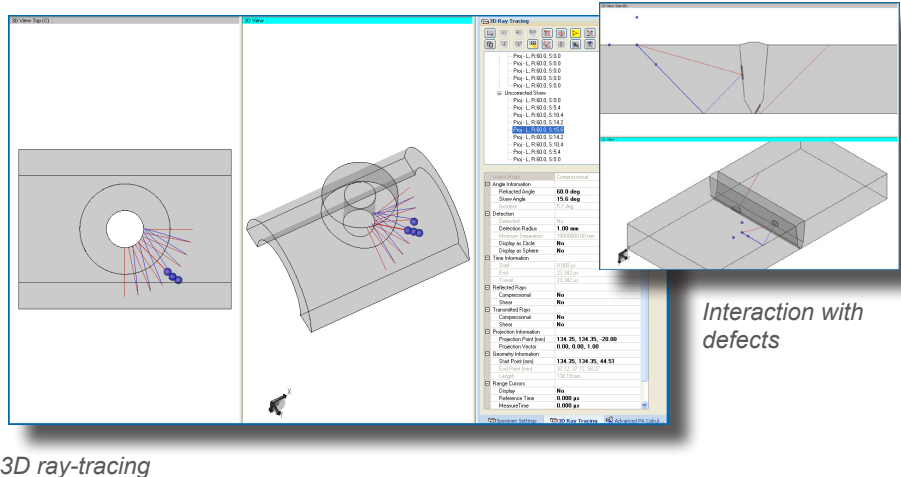

3D ray-tracing

- WELD/SPECIMEN OVERLAYS - 2D & 3D**

Allows you to superpose accurate CAD drawings of the weld or specimen geometry on the examination data, in 2D or 3D views.

- SCANNER TOOL**

Allows you to create a probe manipulator on your component. The scanner and its motion will help you determine the inspection coverage, and will allow for accurate 3D visualization of data on complex components such as saddle welds. The tool provides you with additional information on the motion of the probe on the component surface, and the propagation of the ultrasound during the motion.

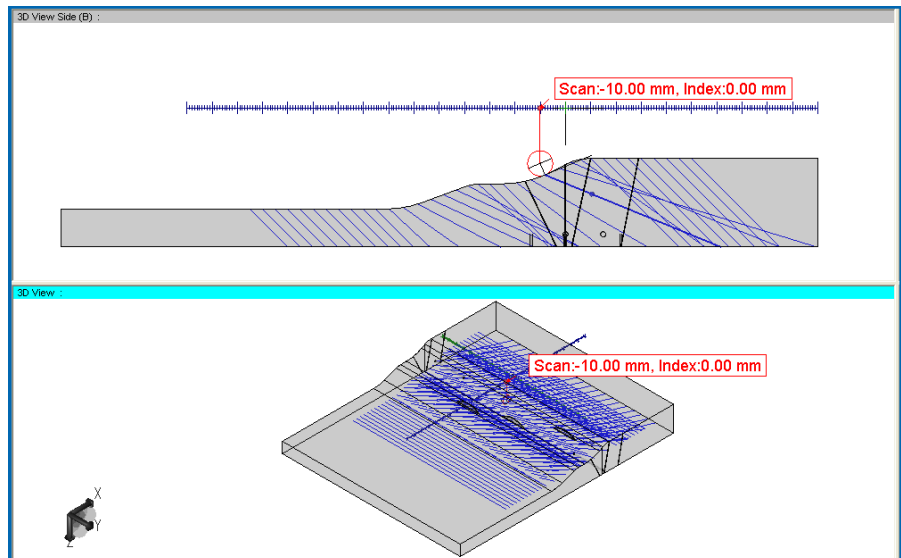

Scanner with ray-tracing (coverage map determination) on a complex specimen with defects and overlay

# UltraVision® 3

## Advanced Data Analysis

- VOLUMETRIC MERGE**

Allows merging of the ultrasonic data acquired with various acoustic beams. This merging process compares the amplitudes obtained in each point of the inspected volume by the considered channels and/or focal laws, and creates a new data group with the maximum amplitude observed at each position in the inspected volume. The tool is also used to merge the data within a specimen for the 3D visualization.

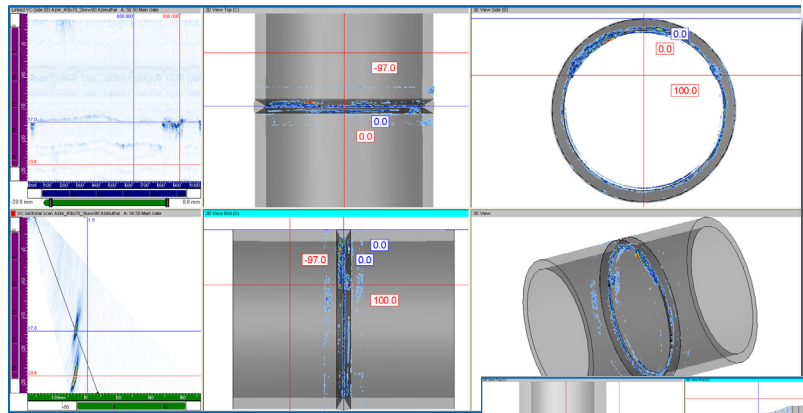

Pipe butt weld data in 3D

- 3D DATA VISUALIZATION**

You can merge the acquired data within your defined specimen for 3D visualization and accurate positioning of relevant indications.

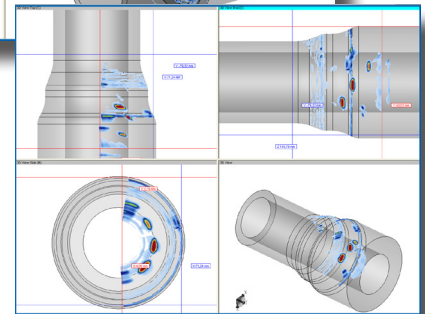
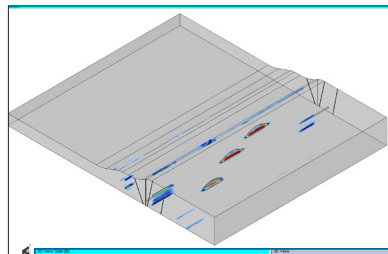

Complex cylindrical parts

- ASSISTED ANALYSIS**

Provides automatic detection of indications based on user-defined criteria such as signal-to-noise and minimum indication size.

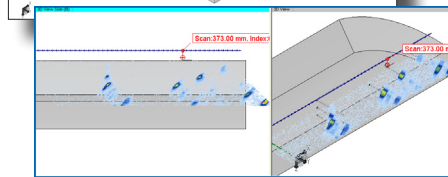

Flat, curved and wavy surfaces

- INDICATION TABLE**

Allows you to create a list of relevant indications. For each entry, you can select a set of information fields (size, amplitude, location, etc) that will be associated with the indication. You can assign a status (flaw, geometry, etc), attach a screen capture of the indication and generate reports.

Id	Comments	C Scan2-Scan1-6 dB	C Index2-Index1-6 dB	Max Amp	Mean Amp	State
001	Auto Value					Unknown
001	Indication 001	20.800 mm	3.00 mm	100.0 %	4.2 %	Geometric
002	Indication 002	25.600 mm	3.60 mm	100.0 %	2.2 %	Flaw
003	Indication 003	27.200 mm	4.80 mm	100.0 %	2.2 %	Geometric
004	Indication 004	17.600 mm	8.40 mm	100.0 %	2.2 %	Unknown

Indication Table

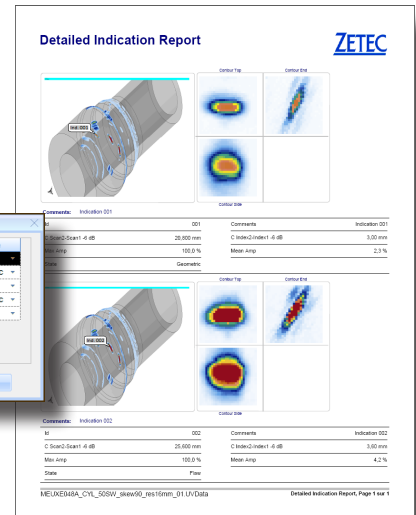

Comprehensive reports

- REPORTING**

Allows you to create professional and comprehensive reports, containing acquisition configuration settings, and the information listed in the indication table.

- ADVANCED SIGNAL PROCESSING TOOLS**

UltraVision 3 provides signal processing tools for Hysteresis Correction, Geometric Echo Removal, and Logarithmic/Linear data conversions.

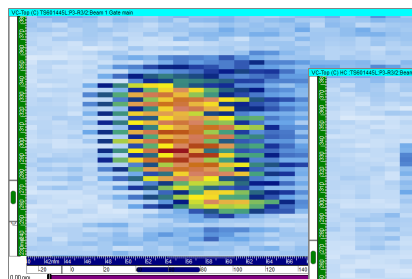

Hysteresis Correction

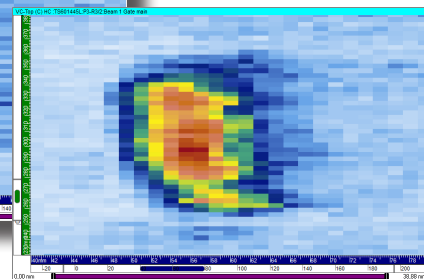

# UltraVision® 3

## Optimized Inspection for your Components

- BEAM SIMULATION**

Allows you to compute, visualize and characterize the energy distribution in the acoustic beam generated by a given probe : single element (conventional UT), 1D linear array, 2D matrix array. The specimen can be flat, cylindrical or complex and made of a material from the predefined list or a user defined material.

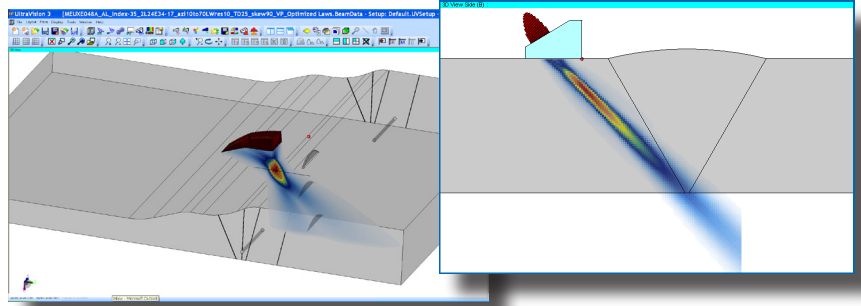

3D beam simulation on complex specimen with Flexible probe

- ADVANCED FOCAL LAW CALCULATOR**

Allows you to generate adequate phased array beams for 1D and 2D array probes, as well as flexible array probes. Using the 3D display of the probe configuration and the specimen, you can verify and validate the inputs and the resulting focal laws.

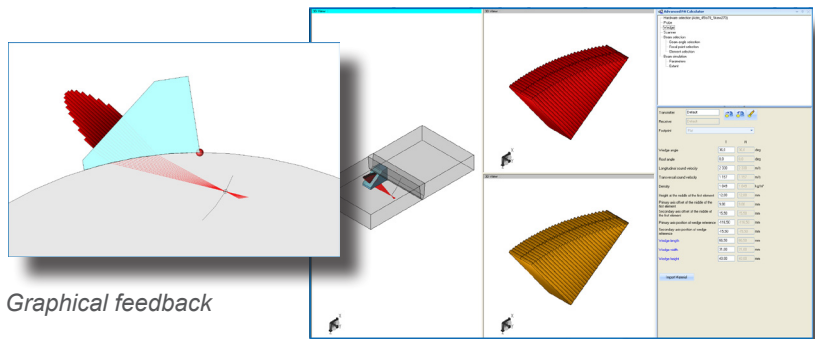

Graphical feedback

- POSITION DEPENDANT FOCAL LAWS**

This tool allows you to create position dependant focal laws, synchronizing different sets of focal laws in different areas of a specimen with varying complex geometry. It will apply the appropriate focal laws based on the current manipulator position (scan and index axes).

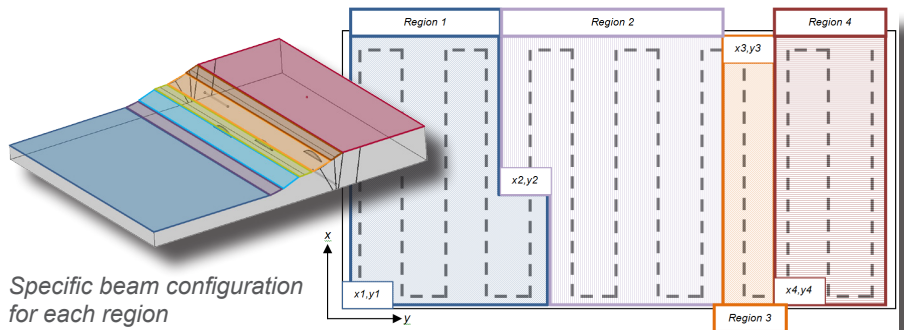

Specific beam configuration for each region

- CALIBRATION TOOL**

Allows you to perform automated calibration (amplitude, time base) and TGC creation for both conventional UT and phased array UT configurations.

- VOLUMETRIC DYNAMIC VIEWS**

Real-time display of various view type: From Top-, Side- and End-views to Dynamic Polar view and Sectorial Scan. Fully customizable layouts can be created and saved with overlays, information fields, color palette, software gain settings and more.

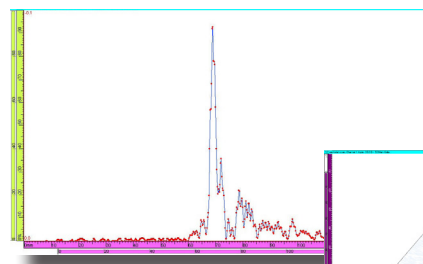

Online A-Scan

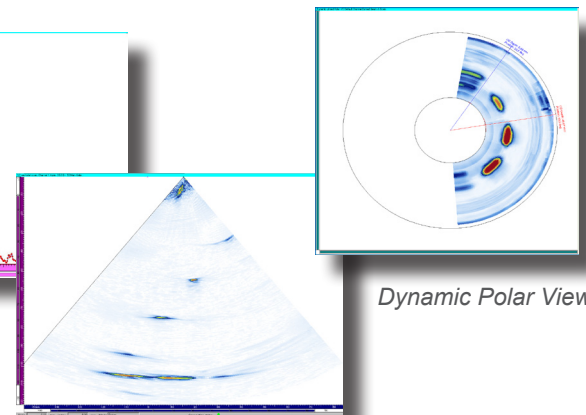

Dynamic Polar View

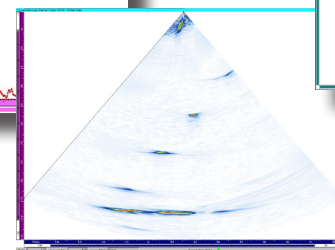

Sectorial Scan

# UltraVision® 3

## Reliable and Secure

- USER RIGHTS ACCESS**

The administrator of the software can create new users and assign them different software access capabilities. This allows essential UT parameters settings to be secured by procedure developers, while leaving other parameters accessible for site operators with limited training.

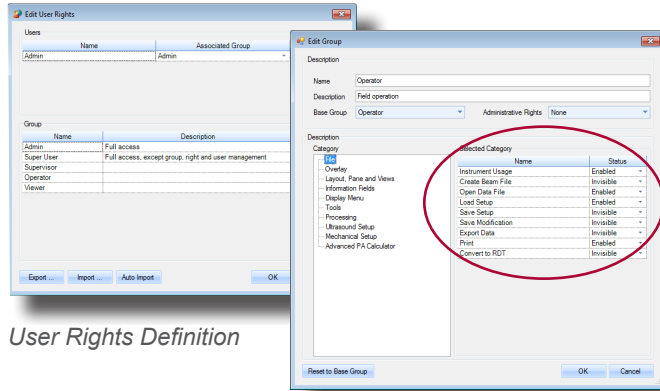

*Invisible, Read Only or Enabled parameters and functions*

User Rights Definition

- LOG VIEWER**

You can create a log that will register user actions and system events with a time stamp and a complete description of the logged events, thus allowing you to review the tasks performed with UltraVision 3.

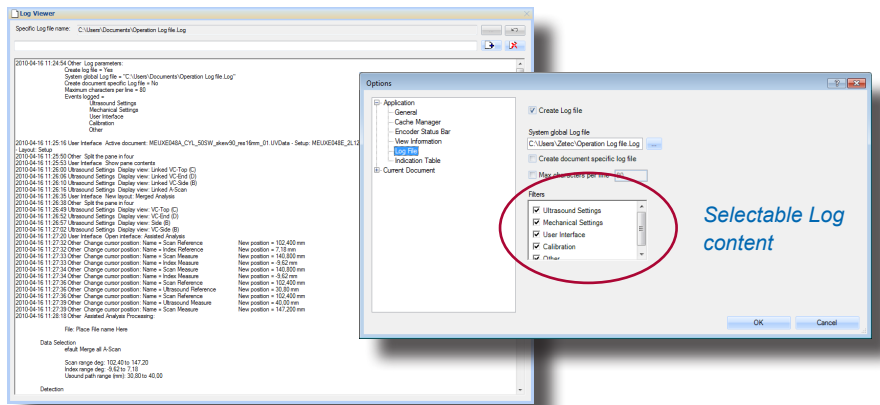

*Selectable Log content*

Log Viewer

- ESSENTIAL PARAMETERS**

Readily available in analysis mode for verification by data analyst: Ultrasound Settings, Mechanical Settings, ...

- RAW DATA PROTECTION**

Parameter modifications and processed data are stored in extension files to protect the integrity of the original raw data.

- MESSAGE BOARD**

Presents useful information such as the validity of your instrument calibration, or site license renewal information.

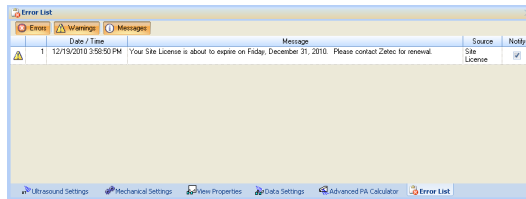

*Software license, calibration status, etc.*

Message Board

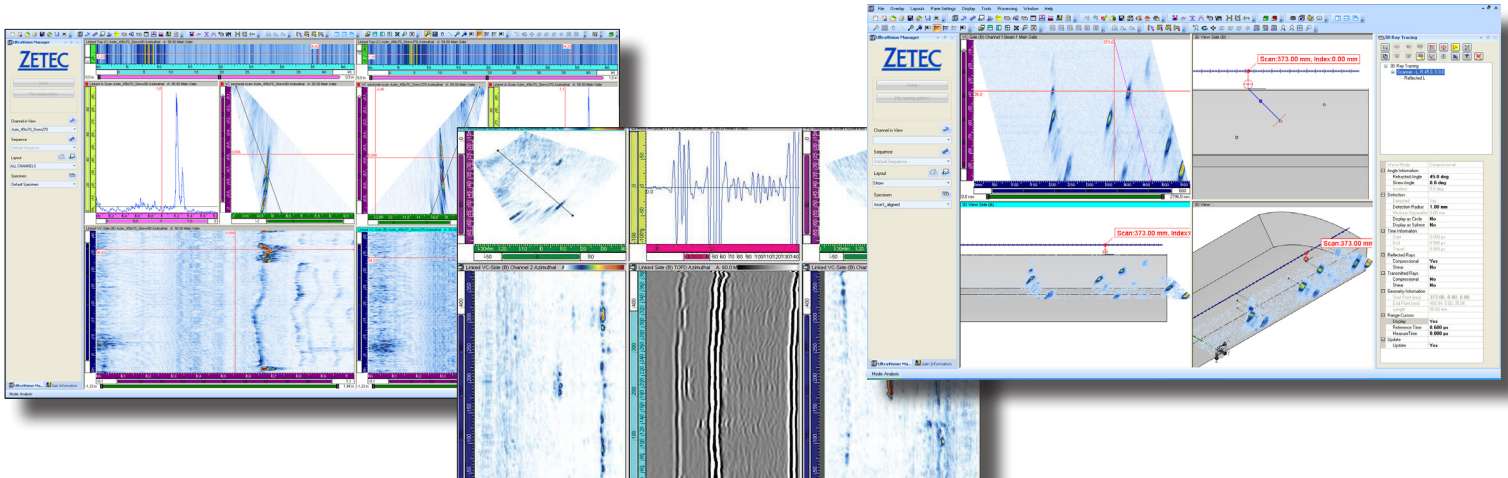

# UltraVision® 3

All the tools of UltraVision 1... and a lot more!

## Feature Comparison Chart

	UltraVision 1		UltraVision 3		
	Basic	Full	Basic	Advanced	3D
<b>SETUP and ACQUISITION</b>					
Z-Scan PA, Tomoscan III UT and PA, OmniScan PA, µTomoscan and Focus	✓	✓			
Z-Scan UT	✓	✓	✓	✓	✓
ZIRCON™, DYNARAY® and DYNARAY® Lite			✓	✓	✓
Basic Self Diagnostic with DYNARAY® and DYNARAY® Lite			✓	✓	✓
Automatic probe detection with the ZIRCON™			✓	✓	✓
DDF	✓	✓	✓	✓	✓
Position dependant focal laws					✓
Automated PA calibration and TGC	✓	✓	✓	✓	✓
Parameter access management (User Rights)	✓	✓	✓	✓	✓
Operation logging (Log Viewer)	✓	✓	✓	✓	✓
<b>ADVANCED FOCAL LAW CALCULATOR</b>					
Graphical feedback on focal law generation	✓	✓	✓	✓	✓
Acoustic beam simulation		✓		✓	✓
Focal law calculation on flat and cylindrical specimens	✓	✓	✓	✓	✓
Support of complex geometries					✓
1D and 2D flexible array and custom contoured wedges					✓
<b>SPECIMEN and OVERLAY MANAGEMENT</b>					
2D specimen overlay in Top, Side and End views	✓	✓	✓	✓	✓
3D specimen (Specimen generator, 3D Overlay, Visualization of UT data)					✓
Scanner creation tool					✓
3D ray-tracing with postulated defects					✓
<b>TOFD</b>					
Calibration (flat and cylindrical) and processing (LW Synchronization, LW Removal, SAFT)	✓	✓	✓	✓	✓
<b>DATA FILES</b>					
Up to 1 GB	✓	✓			
Up to 20 GB			✓	✓	✓
<b>ANALYSIS</b>					
Basic (measurement tools) and Advanced (indication table) analysis features	✓	✓	✓	✓	✓
Volumetric Merge	✓	✓	✓	✓	✓
3D Volumetric Merge					✓
Assisted Analysis		✓		✓	✓
Off-line hysteresis (backlash) correction	✓	✓	✓	✓	✓
Geometrical echo removal tool		✓		✓	✓
Reporting feature	✓	✓	✓	✓	✓
Retrieval and visualization of DAT (Tomoscan), RDT, OPD and OUD (OmniScan) data files	✓	✓	✓	✓	✓
Retrieval and visualization UVDATA and BEAMDATA data files			✓	✓	✓
<b>ADDITIONAL</b>					
Multi-language operation			✓	✓	✓
Open architecture / Software Development Kit (SDK)				✓	✓
Site License	✓	✓	✓	✓	✓



ZETEC holds ISO 9001:2008  
and ISO/IEC 17025:2005  
certifications



875 boul. Charest Ouest, Suite 100  
Québec, Qc, CANADA G1N 2C9

Toll free: 800.643.1771

P: 418.266.3020

F: 418.263.3742

[www.zetec.com](http://www.zetec.com)